

SPECIFICITIES

- Reduction of waste volume = less frequent collection.
- Custom built (slope, length, intake hopper dimensions, etc.).
- Can be used with our entire range of bar screens.
- Simple design, low operating costs and easy maintenance.

TECHNICAL CHARACTERISTICS

	VCP 150	VCP 200	VCP 250
Max. Flow (m3/h)	0,5	1	2
Reduction in Waste Volume (%)	50		
Dryness (%)	30 to 35		
Max. Slope (°)	20	25	20
Max. Length (mm)	2 000	6 000	8 000
Material	304L or 316L		
Electrical Protection	Current Controller		



1 • PRESS UNIT

- Length of 300 mm on the VCP150, 500mm on the others
- Basket made of sheet with 60x4 mm perforations
- Adjustable compression flap
- Inspection door
- 1/4 turn manual valve, 3/4" coupling, female (optional)
- Electro-valve (optional)
- Cleaning nozzles (x4)
- Washing rate at 4 bars = 36 L/min (intermittent)

2 • INTAKE HOPPER

Custom built

3 • FILTRATE OUTPUT

DN65

4 • OUTPUT HOPPER

5 • CONVEYING AREA

	VCP150	VCP200	VCP250
Ø of trough (mm) :	170	225	274
Ø of screw thread (mm) :	150	200	250
Flat section :	50x10	70x12	80x20
Wear strip : HD500 6 mm thick			

6 • GEARED MOTOR (SEW)

	VCP150	VCP200	VCP250
Power (kW) :	0,12	0,25 to 1,10	0,55 to 1,50

7 • ADJUSTABLE LEGS

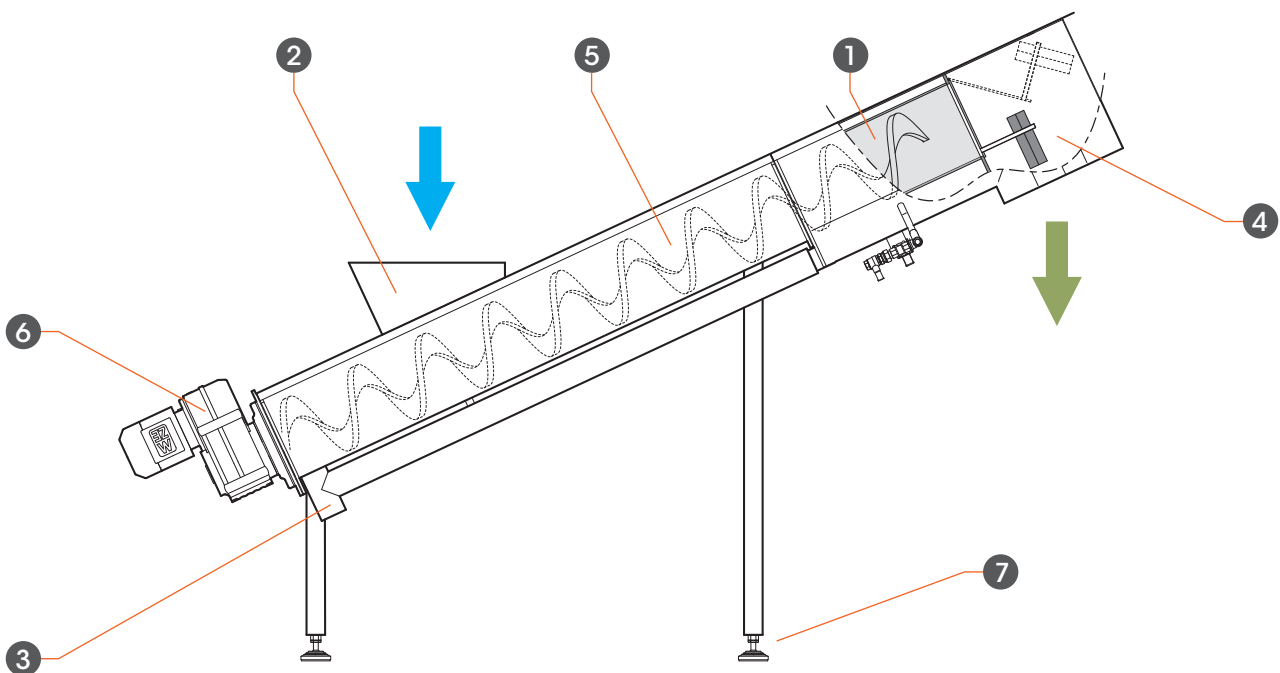

OPERATING PRINCIPLE

Waste is dumped in the conveying area through the intake hopper, adapted to the equipment which supplies it. The rotation of the Archimedes shaftless screw directs the waste to the compacting area where it accumulates against the compression flap held closed by a counterweight. Once the pressure is sufficient, this flap opens and the compacted waste is dumped into a receiving container (automatic bagging system, waste container, vertical duct or other).

The compacting area, equipped with a basket made of perforated sheet, is intermittently cleaned (workshop setting: 1 minute every three or four hours) by means of the four cleaning nozzles. The drained water, both in the conveying and compacting area, is recovered by a tube welded under the entire length of the screw. The filtrates can also be sent to the channel or station.

OPTIONS

Extension of output hopper, bagging head, automatic bagging system with 70-meter plastic bag refills, manual valve & electro-valve (for compacting and/or conveying area cleaning nozzles), safety end of travel sensors on press unit inspection door, waste washing ramp in conveying area, etc.